

236 E. Pima Street  
Suite 104  
Phoenix, AZ 85004  
www.waremfginc.com  
www.sierra-mfg.com

**WARE**  
Manufacturing Inc.

**SIERRA**  
By Ware Manufacturing, Inc.

Instruction #6098  
Revised 04/12/04

# A-Frame Dog House • Assembly Instructions

Tools Required: Screwdriver

## Parts For Large & Medium A-Frame:

- 1 - Floor (A)
- 2 - Sides (B)
- 1 - Front (C)
- 1 - Back (D)
- 2 - Roof Panels (E)
- 1 - Metal Roof Cap (F)
- 20 - 1 1/2" Bolts (if black bolts included, use on roof)
- 12 - Wing-Nuts
- 8 - Wood Screws

## Parts For Small A-Frame:

- 1 - Floor (A)
- 2 - Sides (B)
- 1 - Front (C)
- 1 - Back (D)
- 2 - Roof Panels (E)
- 1 - Metal Roof Cap (F)
- 8 - 1 1/2" Bolts (if black bolts included, use on roof)
- 8 - Wing-Nuts
- 6 - Wood Screws

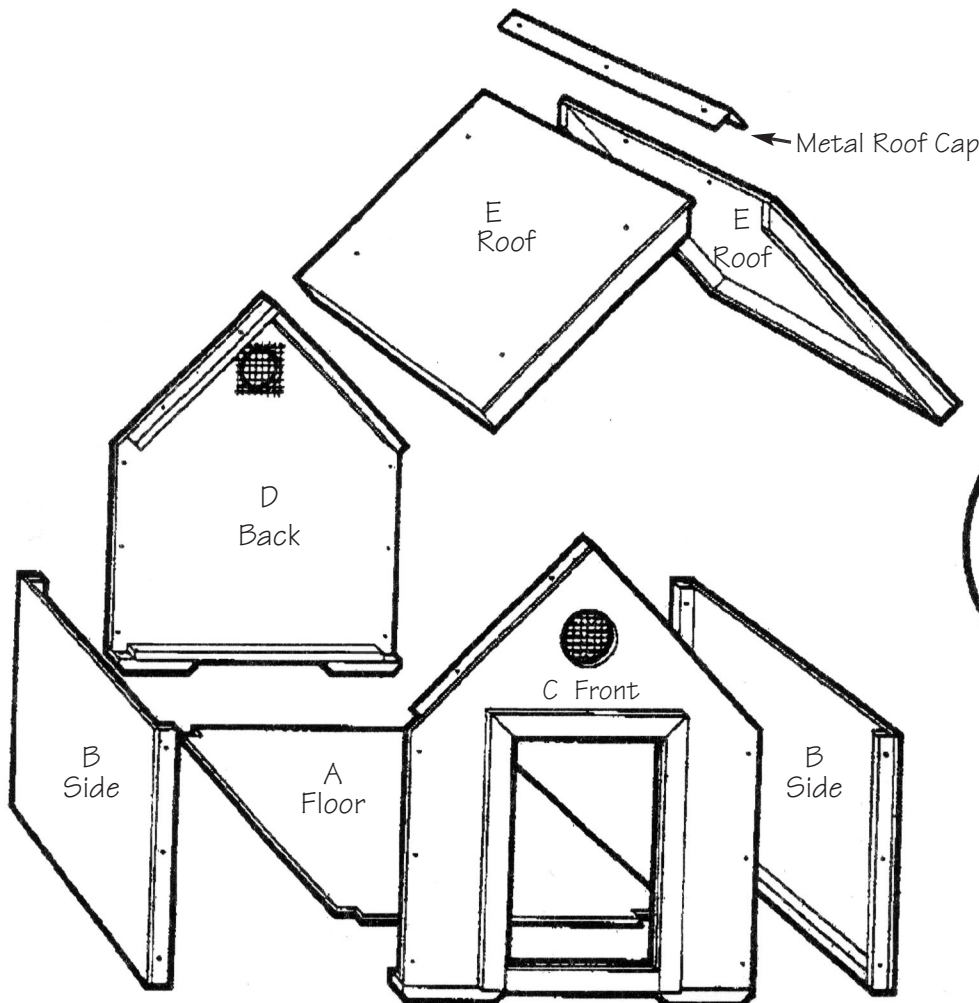
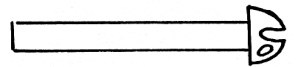

**STEP 1**

Attach Front (C) to Right Side (B) and Left Side (B)

**Use 1 1/2" Bolts**

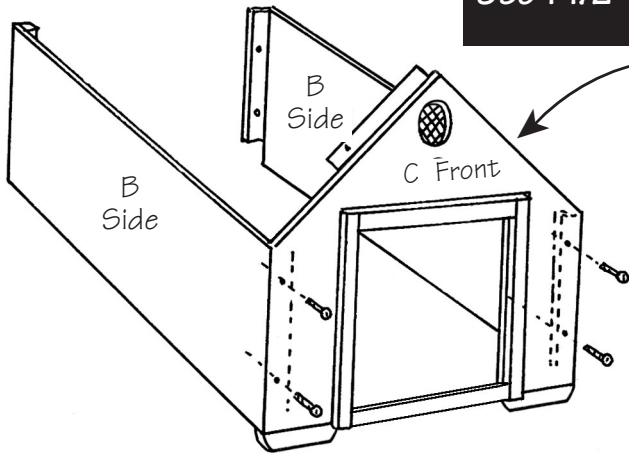

**STEP 2**

Attach Back (D) to Right Side (B) and Left Side (B)

**Use 1 1/2" Bolts**

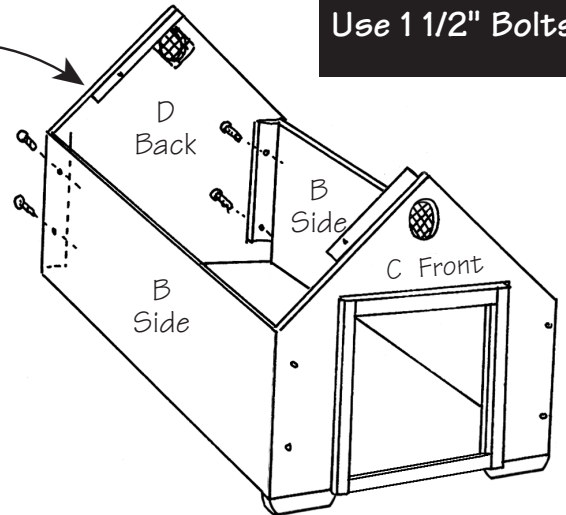

**Roof Supports Must Face Inward**

**STEP 3**

Place Floor (A) Through the Top Assembly Smooth Side Up.

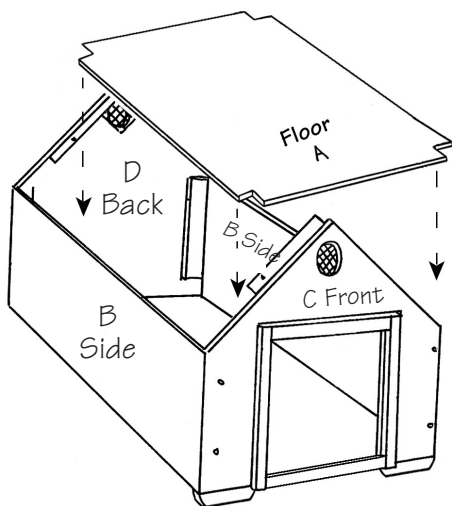

**STEP 4**

Attach Roof Panels (E) to Front (C) and Back (D) Supports.

**Use 1 1/2" Bolts**

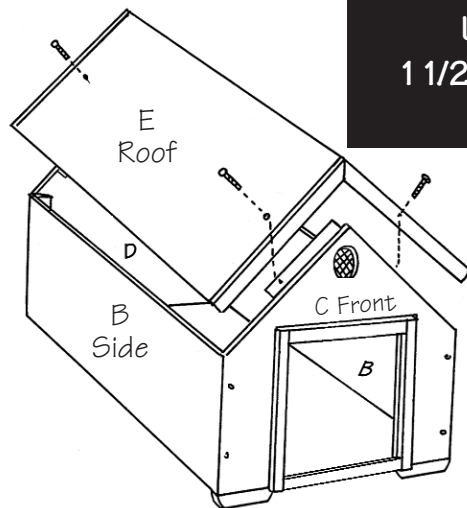

**STEP 5**

Attach Metal Flashing (F) to Roof as Shown Below.

**Use Wood Screws**

